

Caster Add-On to Lightweight Durable Floor Standing Divider

ASSEMBLY INSTRUCTIONS

READ ALL INSTRUCTIONS BEFORE YOU BEGIN. DO NOT JUMP AHEAD OF ANY STEP.

PARTS LIST:

Locking Caster
(4 pcs)

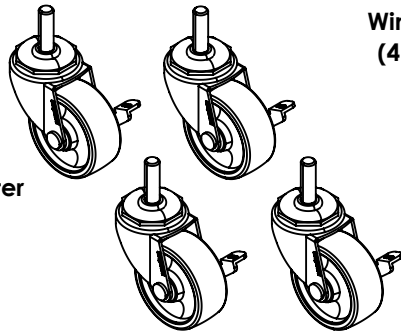

Wingnut
(4 pcs)



Lock Washer
(4 pcs)



Washer
(4 pcs)



Add-On Kit to be used with Lightweight
Durable Floor Standing Dividers
13801 / 13802 / 13803

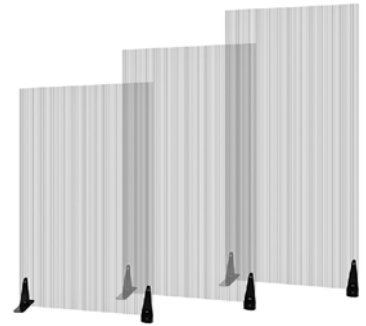

*NO TOOLS REQUIRED

*TWO PERSON ASSEMBLY RECOMMENDED

STEP 1: With the help of another person, carefully tilt your Floor Standing Divider back and lay it down on a flat surface.

STEP 2: Take one of the Locking Casters and insert the stem of the caster into the pre-drilled hole on the bottom of one of the metal brackets of your Divider. Once inserted, follow with (1) Washer, (1) Lock Washer and (1) Wingnut on the other side to secure in place.

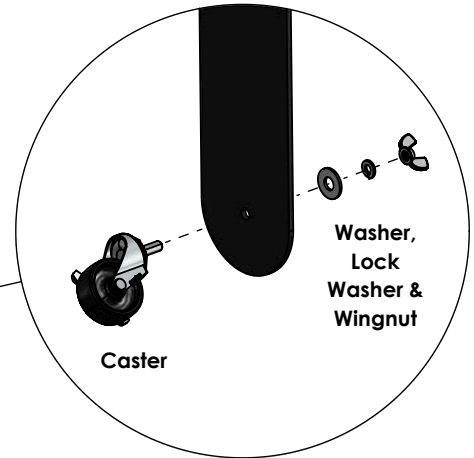
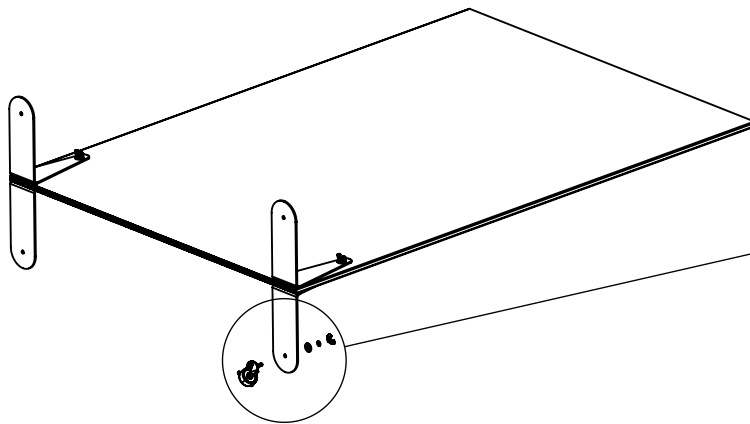

Insert stem of Caster into hole in bottom of Metal Bracket.

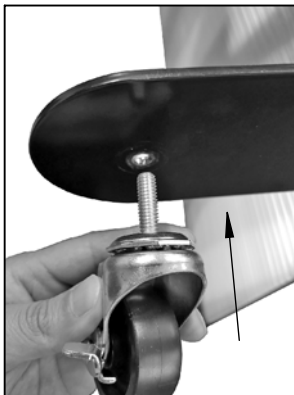

Add Washer and Lock Washer on top of Caster stem.



Add Wingnut and fully tighten. **Lock the brake on caster after installed.**

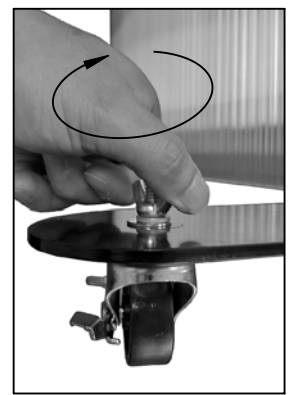

Caster Add-On to Lightweight Durable Floor Standing Divider

ASSEMBLY INSTRUCTIONS

READ ALL INSTRUCTIONS BEFORE YOU BEGIN. DO NOT JUMP AHEAD OF ANY STEP.

STEP 3: Repeat STEP 2 to install remaining Locking Casters on other 3 metal brackets. **Again, make sure to lock the brake on each caster once installed.**

STEP 4: With the help of another person, carefully tilt your Floor Standing Divider back up straight until all 4 casters are firmly sitting on your flat surface. Check each caster to ensure it is securely installed and tighten wingnuts as needed. Unlock brakes on casters to move your Divider around freely. Once your Floor Standing Divider is in its desired location, lock all 4 casters by pressing down on the brakes.

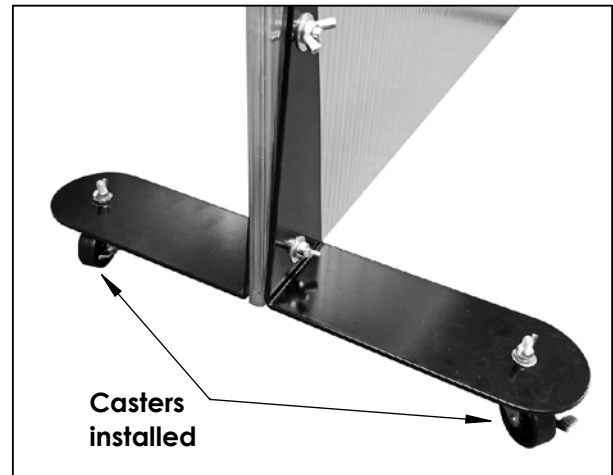

ASSEMBLY COMPLETED

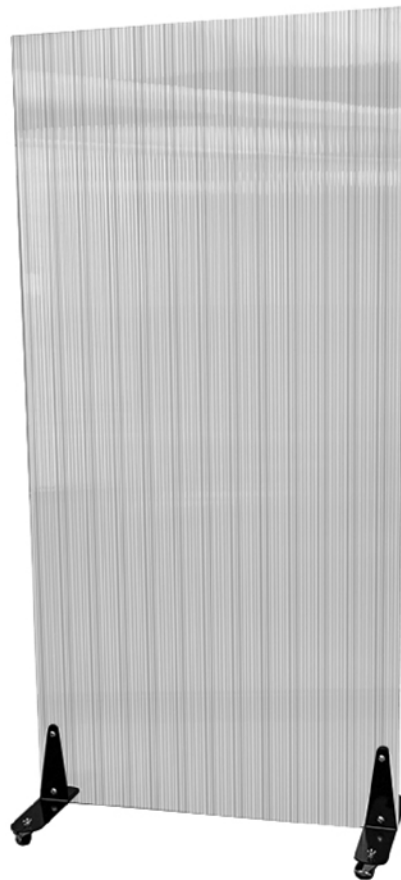

13801 / 13802 / 13803

with Set of 4 Casters Kit
(13810)